

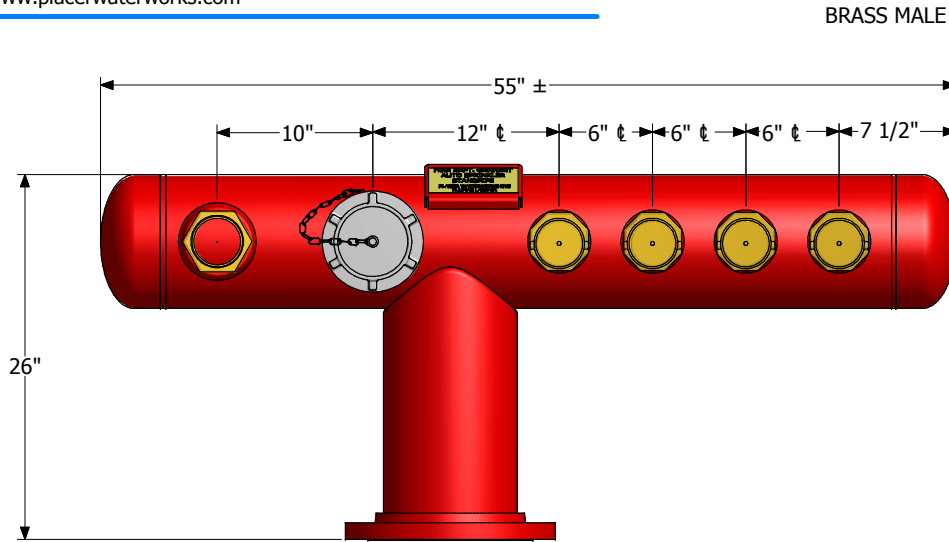

1325 Furneaux Road, Plumas Lakes, CA. 95961
(530) 742-9675
www.placerwaterworks.com

STORZ FIRE DEPARTMENT CONNECTION w/ BRASS CLAPPER SNOOTS & ADAPTER



BRASS MALE TO MALE ADAPTER 4 1/2" x 4"
CROKER NO: 7201 OR EQUAL

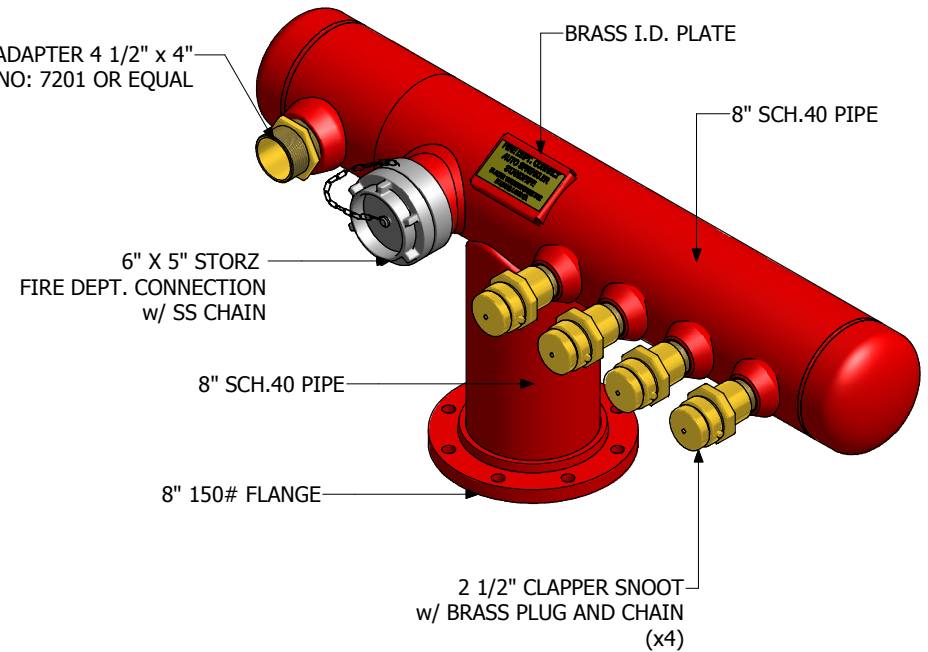

NOTES:

1. VERTICAL PIPE IS 8" A-53, SCHEDULE 40 BLACK TYPE.
2. NPT NIPPLE WELDED FIRST - A ROOT PASS.
SECOND, FILLET PASS. FINISH WITH A 3/8" FINAL PASS.
3. PIPE CAPS AND PIPE TO PIPE CONNECTION TO BE 100% PENETRATION.
4. WELDING TYPE: SEMI-AUTOMATIC NR 211 INNER SHIELD WIRE PER SECTION 9 ASME CODE.
5. 150# SLIP ON RAISED FACE FLANGE WELDED INSIDE W/ 1/4" FILLET AND EXTERIOR TO HAVE 3/8" FILLET WELD.
6. (1) 6" X 5" STORZ INLET FIRE DEPT. CONNECTION WITH BLIND CAP & (1) 4-1/2" X 4" MALE TO MALE ADAPTER.
7. CORROSION PROTECTION ACHIEVED THROUGH WHITE METAL GARNET BLAST W/ 5 TO 7 MILS OF RED BAKED POWDER FINISH.
8. ALL WELDING IS DONE PER AWS D1.1 SECTION 3 FCAW PROCESS.
9. NOT RECOMMENDED FOR WET SYSTEM.
10. UL APPROVED BRASS CLAPPER SNOOTS
11. ABOVE UL INFORMATION IS FOR "BRASS CLAPPER SNOOTS" ONLY

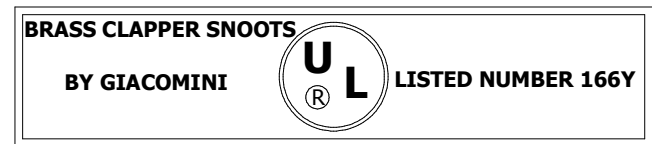

11

CAT#: Custom: STORZ FIRE DEPARTMENT CONNECTION -w- BRASS CLAPPER SNOOths & ADAPTER
Copyrighted 2014 Placer Waterworks, Inc.© All Right Reserved - For Duplication Authorization may obtain thru: kkern@placerwaterworks.com

*** CB: R.V. 02/11/2014 REV.02