

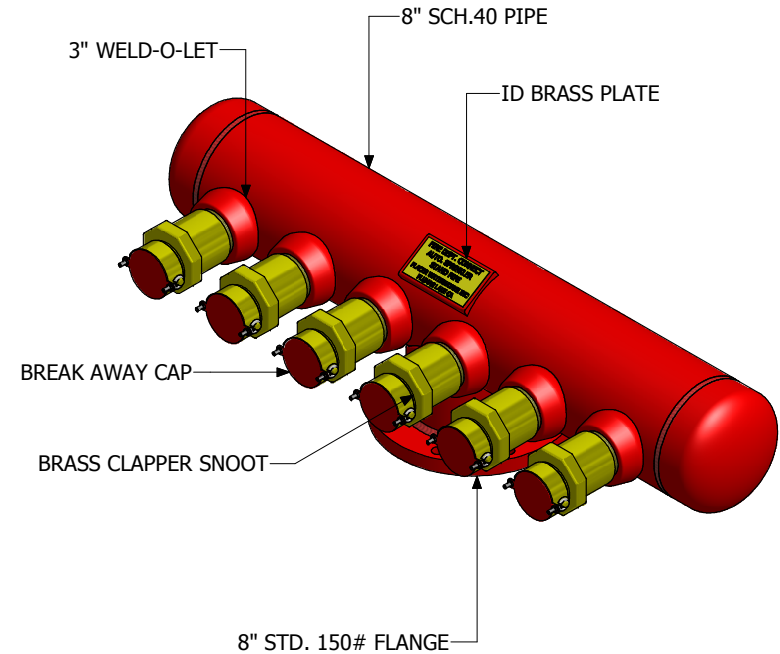

1325 Furneaux Road, Plumas Lakes, CA. 95961  
(530) 742-9675  
www.placerwaterworks.com

# 8" (6 PORTS) FIRE DEPARTMENT CONNECTION PW/FDC-6138

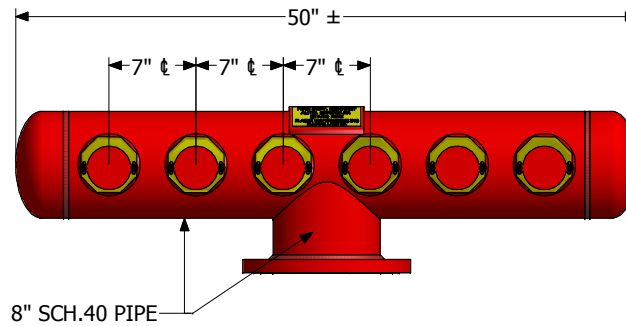
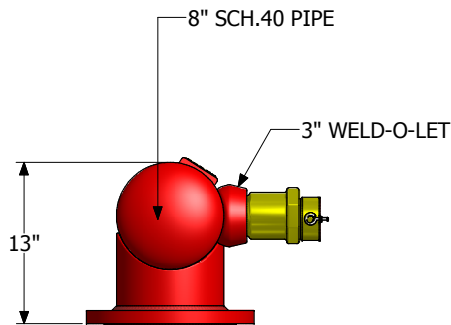

**NOTES:**

1. ALL HORIZONTAL & VERTICAL PIPE IS 8" A-53, SCHEDULE 40 BLACK TYPE.
2. 3" WELD-O-LETS WELDED ON 7" CENTERS WITH FIRST - A ROOT PASS. SECOND, FILLET PASS. FINISH WITH A 3/8" FINAL PASS.
3. PIPE CAPS AND PIPE TO PIPE CONNECTION TO BE 100% PENETRATION.
4. WELDING TYPE: SEMI-AUTOMATIC NR 211 INNER SHIELD WIRE PER SECTION 9 ASME CODE.
5. 150# SLIP ON RAISED FACE FLANGE WELDED INSIDE W/ 1/4" FILLET AND EXTERIOR TO HAVE 3/8" FILLET WELD.
6. ABOVE UL INFORMATION IS FOR "BRASS CLAPPER SNOOTS" ONLY
7. BRASS CLAPPER SNOOT'S TO HAVE BRASS PLATED FINISH
8. ENTIRE FIXTURE IS ABRASIVE BLASTED SSPC SP-5 WHITE METAL BLAST 2-3 MIL ANGULAR PROFILE THEN POWDER COATED RED W/ 4-6 MILS FILM THICKNESS.
9. ALL WELDING IS DONE PER AWS D1.1 SECTION 3 FCAW PROCESS.
10. NOT RECOMMENDED FOR WET SYSTEM.

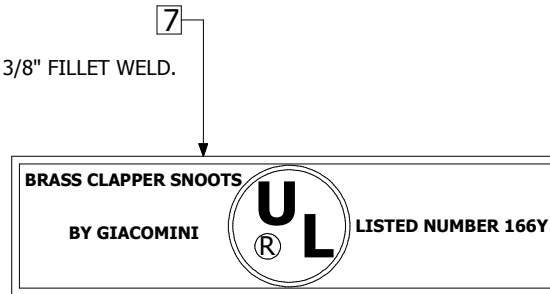

CAT#: PW/ FDC-6138: 8" (6 Ports) Fire Department Connection  
Copyrighted 2015 Placer Waterworks, Inc. © All Right Reserved - For Duplication Authorization may obtain thru: kkern@placerwaterworks.com

\*\*\* CB: R.V. 03/11/2015 REV. 00