

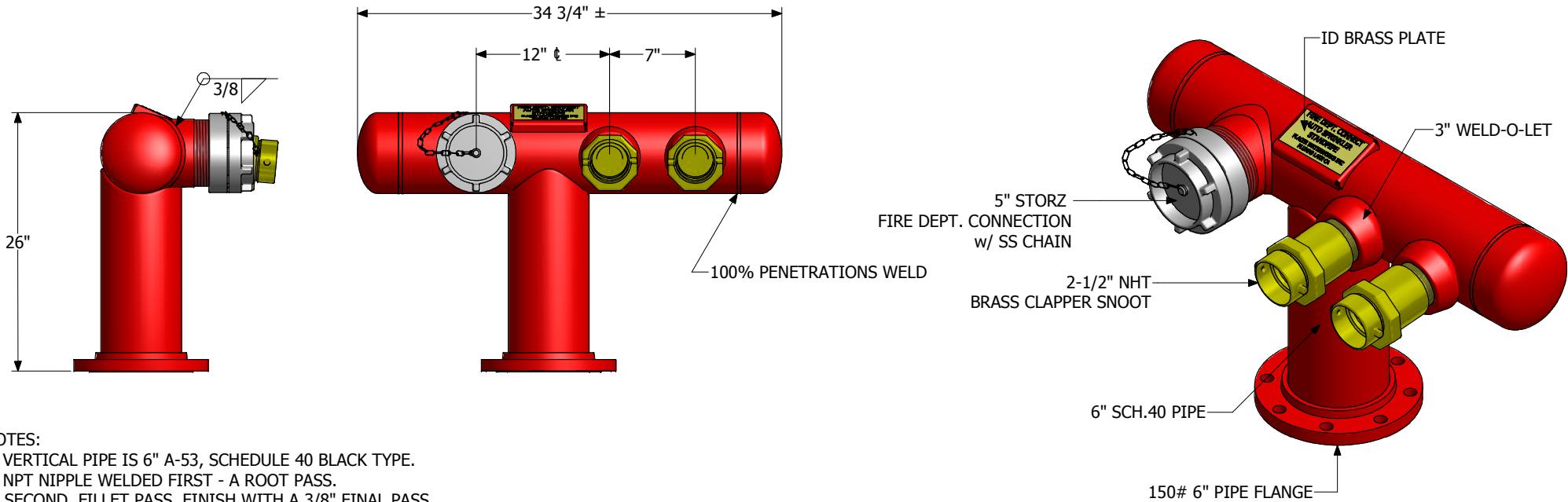

1325 Furneaux Road, Plumas Lakes, CA. 95961  
(530) 742-9675  
www.placerwaterworks.com

# 5" STORZ FIRE DEPARTMENT CONNECTION w/ BRASS CLAPPER SNOOTS



**NOTES:**

1. VERTICAL PIPE IS 6" A-53, SCHEDULE 40 BLACK TYPE.
2. NPT NIPPLE WELDED FIRST - A ROOT PASS.  
SECOND, FILLET PASS. FINISH WITH A 3/8" FINAL PASS.
3. PIPE CAPS AND PIPE TO PIPE CONNECTION TO BE 100% PENETRATION.
4. WELDING TYPE: SEMI-AUTOMATIC NR 211 INNER SHIELD WIRE PER SECTION 9 ASME CODE.
5. 150# SLIP ON RAISED FACE FLANGE WELDED INSIDE W/ 1/4" FILLET AND EXTERIOR TO HAVE 3/8" FILLET WELD.
6. 5" STORZ FIRE DEPT. CONNECTION W/ HARD COATED ALUMINUM ADAPTER W/ STORZ INLET, FEMALE NPT OUTLET.  
HARD COATED ALUMINUM STORZ CAP W/ SS CHAIN ATTACHMENT.
7. CORROSION PROTECTION ACHIEVED THROUGH WHITE METAL GARNET BLAST W/ 5 TO 7 MILS OF RED BAKED POWDER FINISH.
8. ALL WELDING IS DONE PER AWS D1.1 SECTION 3 FCAW PROCESS.
9. NOT RECOMMENDED FOR WET SYSTEM.
10. UL APPROVED BRASS CLAPPER SNOOTS

11. ABOVE UL INFORMATION IS FOR "BRASS CLAPPER SNOOTS" ONLY

CAT#: PW/ FDC-226 STR2

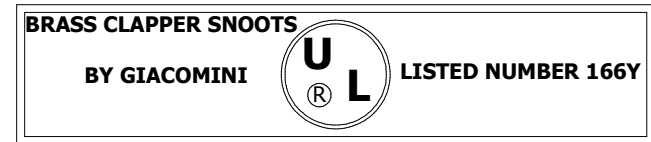

11